



# **Food Plotter No-Till Drill HDNT-65**



## **Operator's Manual**

**Page left blank intentionally**

**TO THE DEALER:**

Assembly and proper installation of this product is the responsibility of the LMC dealer. Read manual instructions and safety rules. Make sure all items on the Dealer's Pre-Delivery and Delivery Check Lists in the Owner's/Operator's Manual are completed before releasing equipment to the owner.

**TO THE OWNER:**

Read this manual before operating your LMC equipment. The information presented will prepare you to do a better and safer job. Keep this manual handy for ready reference. Require all operators to read this manual carefully and become acquainted with all the adjustment and operating procedures before attempting to operate. Replacement manuals can be obtained from your selling dealer. The equipment you have purchased has been carefully engineered and manufactured to provide dependable and satisfactory use. Like all mechanical products, it will require cleaning and upkeep. Lubricate the unit as specified. Observe all safety information in this manual and safety decals on the equipment. For service, your authorized LMC dealer has trained mechanics, genuine LMC service parts, and the necessary tools and equipment to handle all your needs. Use only genuine LMC service parts. Substitute parts will void the warranty and may not meet standards required for safe and satisfactory operation.

Record your implement model and serial number in the space provide below. Your dealer will need this information to give you prompt, efficient service.

**Model Number:** \_\_\_\_\_

**Serial Number:** \_\_\_\_\_

**Date Purchased:** \_\_\_\_\_

# Table of Contents

Introduction .....	5
Technical Specifications .....	5
Safety .....	6
Safety Signal Words .....	6
General Safety Guidelines .....	7
Safety Decal Care .....	7
Before Operation .....	8
During Operation .....	9
Highway And Transport Operations .....	10-11
Attaching to Tractor.....	12
Chain Routing.....	13
Seed Rate Adjustment.....	14
Setting Application Charts.....	15
Calibration Charts.....	16-17
Lubrication and Maintenance .....	18
Torque Specifications .....	19
Parts Breakdown .....	21-41
Warranty .....	42

# Introduction

Thank you for purchasing the HDNT-65 Food Plotter No-Till Drill. The HDNT-65 is the latest, most reliable seeders produced in the US over the past 20 years. High precision seed boxes and flow control make seeding a breeze with the ability to drill many different varieties and sizes of seed into all types of planting conditions. Heavy built, but constructed to be able to be handled by tractors as low as 50 HP, the HDNT-65 is designed for planting deer food plots around woodlands or high precision pasture seeding in the fall.

The 10 coulters at 7 1/2” high precision large seed cups accurately drop seeds into the openings. A separate Legume seed box with high precision seed cups accurately drop seed along a “splash pan” that rains the small seed over the soil. A packer roller system with Nylon rings or **optional Cast Iron rollers** help press the seed into the ground and close up the cuts made by the disc openers.

## Technical Specifications

- Three Point Hitch Cat. 1&2
- Heavy tubular frame construction
- All ground driven, no PTO shaft or gear-box to maintain
- Precise seed metering cups with individual clean out gates
- Rear roller packer rings to firm and smooth seedbed
- Water tight seed box with agitator shaft -calibration chart and seeding rate chart
- 10 Cast Iron double disc openers spaced at 7.5”
- Spring loaded coulters to cut through tough ground
- Optional Cast Iron roller rollers

<b>HDNT-65 Food Plotter No Till Drill</b>	
Weight	1840 lbs.
Req. HP	Minimum 50 HP
Cat. hitch	1 & 2
Double disc openers	10
Row spacing	7 1/2”
Hopper Capacity cu. ft. - front	10.00
Hopper Capacity cu. ft. - rear	2.00

# Important Safety Information

## Safety

It is important that you read the entire manual and to become familiar with this product before you begin using it. This product is designed for certain applications only. The manufacturer cannot be responsible for issues arising from modification. We strongly recommend this product not be modified and /or used for any application other than that for which it is designed. If you have any questions relative to a particular application, DO NOT use the product until you have first contacted us to determine if it can or should be performed on the product.

Read and understand this manual and all safety signs before operating and maintaining . Review the safety instructions and precautions annually.

## Safety Signal Words

**TAKE NOTE! This safety alert symbol found though out this manual is used to call you attention to instructions involving you personal safety and the safety of others. Failure to follow these instructions can result in injury or death.**



**This symbol means:  
Attention!  
Become alert!  
Your safety is involved!**

Note the use of the signal words, DANGER, WARNING and CAUTION with the safety messages. The appropriate signal word for each has been selected using the following guidelines:



**DANGER:** Indicates an imminently hazardous situation that, if not avoided, will result in death or serious injury. This signal word is to be limited to the most extreme situations typically for machine components which, for functional purposes, cannot be guarded.



**WARNING:** Indicates a potentially hazardous situation that, if not avoided, could result in death or serious injury, and includes hazards that are exposed when guards are removed. It may also be used to alert against unsafe practices.



**CAUTION:** Indicates a potentially hazardous situation that, if not avoided, may result in minor or moderate injury. It may also be used to alert against unsafe practices.

# Important Safety Information

## General Safety Guidelines

Safety of the operator is one of the main concerns in designing and developing a new piece of equipment. Designers and manufacturers build in as many safety features as possible. However, every year many accidents occur which could have been avoided by a few seconds of thought and a more careful approach to handling equipment. You, the operator, can avoid many accidents by observing the following precautions in this section. To avoid personal injury, study the following precautions and insist those working with you, or for you, follow them.

Replace any DANGER, WARNING, CAUTION or instruction safety decal that is not readable or is missing. Location of such decals are indicated in this manual. Do not attempt to operate this equipment under the influence of drugs or alcohol.

Review the safety instructions with all users annually.

This equipment is dangerous to children and persons unfamiliar with its operation. The operator should be a responsible adult familiar with farm machinery and trained in this equipment's operations. **Do not allow persons to operate or assemble this unit until they have read this manual and have developed a thorough understanding of the safety precautions and of how it works.**

To prevent injury of death, use a tractor equipped with a Roll Over Protection System (ROPS). Do not paint over, remove or deface any signs or warning decals on your equipment. Observe all safety signs and practice the instructions on them.

Never exceed the limits of a piece of machinery. If its ability to do a job, or to do so safely, is in question - **Don't try it!**



## Safety Decal Care

- Keep safety signs clean and legible at all times.
- Replace safety signs that are missing or have become illegible.
- Replaced parts that displayed a safety sign should also display the current safety sign
- Safety signs are available from your Distributor or Dealer Parts Department or the factory.

# Important Safety Information

## How to install Safety Signs

- Be sure that the installation area is clean and dry.
- Decide on the exact position before you remove the backing paper.
- Remove the smallest portion of the split backing paper.
- Align the decal over the specified area and carefully press the small portion with the exposed sticky backing in place.
- Slowly peel back the remaining paper and carefully smooth the remaining portion of the decal in place.
- Small air pockets can be pierced with a pin and smoothed out using the piece of decal backing paper.



## Before Operation

- Carefully study and understand this manual.
- Do not wear loose-fitting clothing, which may catch in moving parts.
- Always wear protective clothing and substantial shoes.
- Assure that all tires are inflated evenly.
- Give the unit a visual inspection for any loose bolts, worn parts or cracked welds, and make necessary repairs. Follow the maintenance safety instructions included with this manual.
- Be sure that there are no tools lying on or in the equipment.
- Do not use the unit until you are sure that the area is clear, especially of children and animals.
- Don't hurry the learning process or take the unit for granted. Ease into it and become familiar with your new equipment.
- Practice operation of your equipment and its attachments. Completely familiarize yourself and other operators with its operation before using.
- Use a tractor equipped with a Roll Over Protection System (ROPS) and fasten your seat belt prior to starting engine.
- The manufacturer does not recommend usage of tractor with ROPS removed.
- Move tractor wheels to the widest recommended settings to increase stability.
- Securely attach to towing unit. Use a high strength, appropriately sized hitch pin with a mechanical retainer and attach safety chain.
- Do not allow anyone to stand between the tongue or hitch and the towing vehicle when backing up to the equipment.
- Do not use the unit until you are sure that the area is clear, especially of children and animals.



# Important Safety Information



## During Operation

- Children should not be allowed on the product.
- Clear the area of small children and bystanders before moving the feeder.
- If using a towing unit, securely attach feeder by using a hardened 3/4" pin, a metal retainer, and safety chains if required. Shift towing unit to a lower gear before going down steep downgrades, thus using the engine as a retarding force. Keep towing vehicle in gear at all times. Slow down for corners and rough terrain.
- Make sure you are in compliance with all local and state regulations regarding transporting equipment on public roads and highways. Lights and slow moving signs must be clean and visible by overtaking or oncoming traffic when feeder is transported.
- Beware of bystanders, **particularly children!** Always look around to make sure that it is safe to start the engine of the towing vehicle or move the unit. This is particularly important with higher noise levels and quiet cabs, as you may not hear people shouting.
- **NO PASSENGERS ALLOWED!** Do not carry passengers anywhere on, or in, the tractor or equipment, except as required for operation.
- Keep hands and clothing clear of moving parts.
- Do not clean, lubricate or adjust your equipment while it is moving.
- When halting operation, even periodically, set the tractor or towing vehicle brakes, disengage the PTO, shut off the engine and **remove the ignition key.**
- Be especially observant of the operating area and terrain. Watch for holes, rocks or hidden hazards. Always inspect the area prior to operation.
- **DO NOT** operate near the edge of drop-offs or banks.
- **DO NOT** operate on steep slopes as overturns may result.
- Operate up and down (not across) intermediate slopes. Avoid sudden starts and stops.

# Important Safety Information



## Highway and Transport Operations

- Adopt safe driving practices.
- Keep the brake pedals latched together at all times. **Never use independent braking with machine in tow as loss of control and/or upset of unit can result.**
- Always drive at a safe speed relative to local conditions and ensure that your speed is low enough for an emergency stop to be safe and secure. Keep speed at a minimum.
- Reduce speed prior to turns to avoid the risk of overturning.
- Avoid sudden uphill turns on steep slopes.
- Always keep the tractor or towing vehicle in gear to provide engine braking when going downhill. Do not coast.
- Do not drink and drive!
- Comply with state and local laws governing highway safety and movement of farm machinery on public roads.
- Use approved accessory lighting flags and necessary warning devices to protect operators of other vehicles on the highway during daylight and nighttime transport. Various safety lights and devices are available from your dealer.
- The use of flashing amber lights is acceptable in most localities. However, some localities prohibit their use. Local laws should be checked for all highway and marking requirements.
- When driving the tractor and equipment on the road or highway under 40 kph (20 mph) at night or during the day, use the amber warning lights and a slow moving vehicle (SMV) identification emblem.
- Plan your route to avoid heavy traffic.
- Be a safe and courteous driver. Always yield to oncoming traffic in all situations, including narrow bridges, intersections, etc.
- Be observant of bridge loading ratings. Do not cross bridges rated at lower than the gross weight at which you are operating.
- Watch for obstructions overhead and to the side while transporting.
- Always operate in a position to provide maximum visibility at all times. Make allowances for increased length and weight of the equipment when making turns, stopping the unit, etc.
- Pick the most level route when transporting across fields. Avoid the edges of ditches or gullies and steep hillsides.
- Be extra careful when working in inclines.

# Important Safety Information



## Highway and Transport Operations

- Maneuver the tractor or towing vehicle at safe speeds.
- Avoid overhead wires or other obstacles. Contact with overhead lines could cause serious injury or death.
- Avoid loose fill, rocks and holes, they can be dangerous for equipment operation or movement.
- Allow for unit length when making turns,
- Operate the towing vehicle from the operator's seat only.
- Never stand alongside of unit with engine running or attempt to start engine and/or operate machine while standing alongside of unit.
- Never leave running equipment attachments unattended.
- As a precaution, always recheck the hardware on equipment following every 100 hours of operation.  
Correct all problems. Follow the maintenance safety procedures.

# Attaching to Tractor



**Warning:** When attaching the Food Plotter, *Never* allow anyone to stand between the Food Plotter and the tractor. Serious injury or death can occur!

## Attaching the Food Plotter

- Back up the tractor to the Food Plotter, while lining up the lower tractor links to the Food Plotter lower pins.
- Stop the engine, set the brake and remove the key from the tractor and block the tractor tires.
- Secure the tractor lower arms to the Food Plotter lower pins with lynch pins.
- Attach the tractor top link to the Food Plotter with the top link pin and r-clip.
- Adjust the tractor sway bars/chains to center the rotary cutter and remove excess sway.
- Adjust lower links and top link so that the Food Plotter is level.
- Operate the tractor hydraulic controls very slowly up and down. There should be no contact between the Food Plotter or any part of the tractor. Failure to check clearance can result in damage to the Food Plotter, tractor (especially the tires) and possible injury to the operator. Maintain no less than 6” of clearance between the Food Plotter, tractor and tractor tires throughout the complete range of motion.

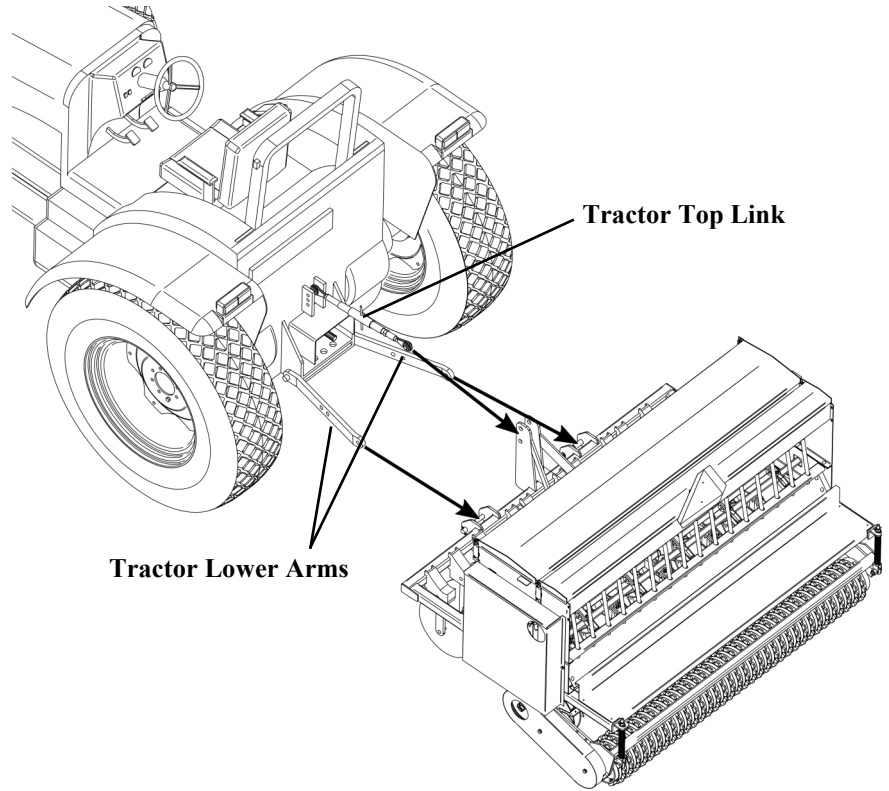

## Operating Instructions

- The top link on the tractor hitch should be properly adjusted to carry the machine level in an operating position. During operation the tractor lift must be fully lowered to allow the machine to follow the contour of the ground.
- The machine is totally ground driven, so proceed with a speed that is most comfortable and safe for existing conditions.
- Be sure to stop forward motion before lifting machine off ground. This practice will stop rollers from ‘free spinning’ and therefore eliminate the unwanted application of when turning around.
- ***Never operate the machine in reverse, serious damage will occur!***

# Chain Routing



**Warning:** Never attempt to adjust or change Food Plotter roller chains when machine is running. Serious injury or death can occur! Before attempting any work on the tractor or implement, shut off tractor engine, remove key and set brake. Block tires if necessary.

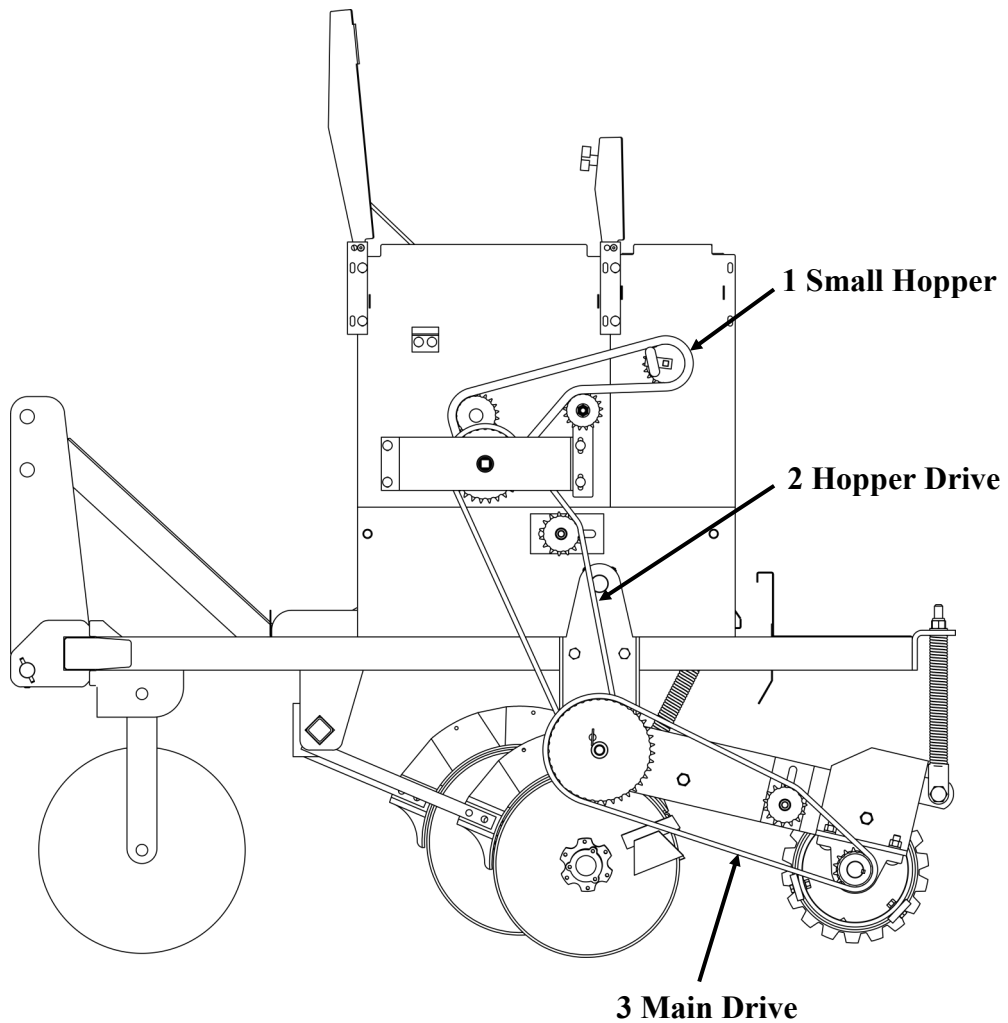

# Seed Rate Adjustment

## Large Hopper

To increase the seed rate, turn the knob on the right side of the hopper clockwise, and lock the jam nuts on the threaded shaft to assure seeding accuracy. Refer to the indicator reading on the square seed shaft and find the corresponding number on the calibration chart to assure you new rate. Reverse this procedure to decrease rate. Remember to rotate the seed shaft while adjusting to prevent damage to cups especially if seeds are in hopper.

**Note:** When seed cups are fully closed, the indicator should be on 0 (on the rule). This can be adjusted by simply adjusting the opener as needed. Fully open would be 1-3/4”.

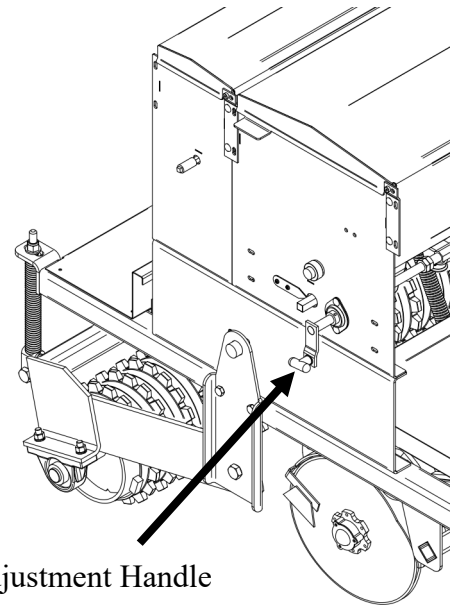

## Small Hopper

The seed rate adjustment for the small hopper is located on the left side of the hopper behind the panel standing at the rear of the machine. To increase the seed rate, turn the knob on the left side of the hopper clockwise and then lock the jam nut. Refer to the indicator reading on the square seed shaft (right side) and find the corresponding number on the calibration chart to assure your new rate. Reverse this procedure to decrease rate. Refer to Charts on pages 16 & 17 of this manual or the rate chart located inside the hopper lid for the corresponding seeding rate.

**Note:** When seed cups are fully closed, the indicator should be on 0 (on the rule). Fully open would be 1-1/8”.

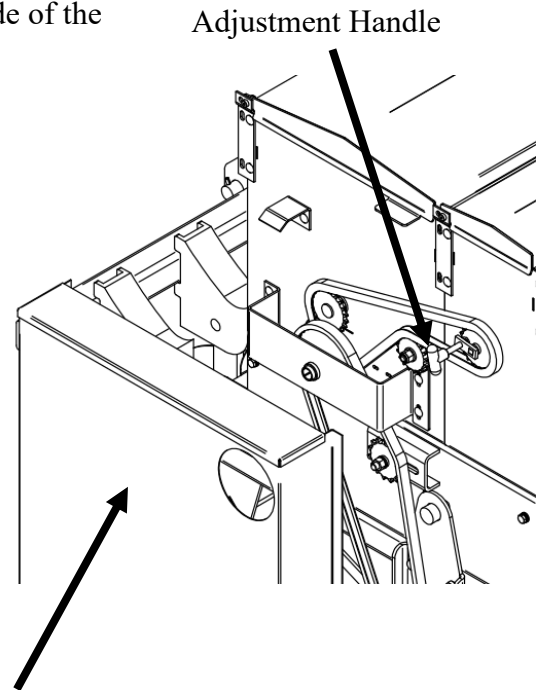

**Warning:** LH Cover removed to show detail only.  
*Never* operate implement unless all shields in place!  
Serious injury or death can occur.

## Setting Application Rates

The most accurate way to set application rates is to drive a predetermined distance and physically catch the seeds dispensed. To do this, remove at least one drop hose and tie a plastic bag onto bottom of seed cup. Travel a determined distance and then weigh the seeds in the bag. Multiply the amount collected by the number of cups on your machine. Refer to the following example to properly calibrate your machine.

To determine area covered calculate the following:

(Disc spacing x number of discs converted to ft.) x distance traveled and then divide by the square feet in an acre.

10 disc with a 7.25" spacing = 72.50" (6.04 ft.) x 500 ft. traveled = 3,020 sq. ft. covered.

43,560 sq. ft. in acre/3,020 = 14.42% of acre covered.

If you collect 16 oz. (1 lb.) of seed from a single seed cup on the #5 setting after driving 500 ft.

(14.42% of an acre), you are putting out 69.35 lbs. per acre.

1 lb. (amount collected) x 10 seed cups = 10 lbs. total output by machine.

Distance traveled = 500 ft. (14.42% of acre)

$1 \times 10 / .1442 = 69.35$  lbs. per acre

NOTE: The tables and rate charts are guidelines only! They are designed to be an aid as a starting point. You must do your own calibration as many factors cause rates to change. Variations in seed/granular size, density, moisture, seed treatment, and the amount of machine overlap will affect the final application rate.

Refer to pages 16 & 17 for "Rate Charts".

# Calibration Charts

## Calibration Chart - Large Hopper - Chart 2

### Seed Cup Position

Seed Type	1/4	1/2	3/4	1	1-1/4	1-1/2	1-3/4	Gate Pos.
<b>Kentucky 31 Tall Fescue</b>	<b>27</b>	<b>51</b>	<b>67</b>	<b>87</b>	<b>105</b>	<b>126</b>	<b>147</b>	<b>top</b>
Annual Rye Grass	39	67	88	118	145	168	183	top
<b>Kentucky Blue Grass</b>	<b>22</b>	<b>36</b>	<b>48</b>	<b>66</b>	<b>78</b>	<b>94</b>	<b>109</b>	<b>top</b>
Perennial Rye Grass	36	57	76	103	126	151	160	top
<b>Creeping Red Fescue</b>	<b>19</b>	<b>33</b>	<b>43</b>	<b>61</b>	<b>73</b>	<b>88</b>	<b>99</b>	<b>top</b>
Rebel III Fescue	25	43	57	91	109	130	147	top
<b>Pennington Contractor's Mix</b>	<b>30</b>	<b>46</b>	<b>63</b>	<b>90</b>	<b>109</b>	<b>130</b>	<b>145</b>	<b>top</b>
Orchard Grass	15	25	34	52	64	75	82	top
<b>Wheat</b>	<b>73</b>	<b>126</b>	<b>172</b>	<b>214</b>	<b>252</b>	<b>295</b>	<b>330</b>	<b>top</b>
Oats	30	61	94	130	163	187	213	top
<b>Fertilizer 10-10-10</b>	<b>88</b>	<b>151</b>	<b>199</b>	<b>297</b>	<b>367</b>	<b>430</b>	<b>472</b>	<b>middle</b>
Top Dress 16-0-0	105	183	246	367	451	535	687	top

## Calibration Chart - Small Hopper - Chart 3

### "lbs. per acre"

Seed Type	3/16	1/4	3/8	1/2	3/4	1	1-1/8
<b>Pennsicola Bahai</b>	<b>4</b>	<b>9</b>	<b>12</b>	<b>16</b>	<b>21</b>	<b>30</b>	<b>33</b>
Centipede	6	9	15	22	34	43	51
<b>Hulled Bermuda</b>	<b>6</b>	<b>10</b>	<b>16</b>	<b>24</b>	<b>36</b>	<b>48</b>	<b>55</b>
Red Clover	7	12	19	25	43	55	67
<b>Landino Clover</b>	<b>6</b>	<b>10</b>	<b>19</b>	<b>25</b>	<b>40</b>	<b>54</b>	<b>63</b>
Dixie Crimson	7	12	19	25	43	55	67
<b>White Millet</b>	<b>4</b>	<b>12</b>	<b>19</b>	<b>25</b>	<b>42</b>	<b>54</b>	<b>64</b>
Total Alfalfa	7	12	19	24	40	52	61
Carpet Grass	4	9	13	24	30	37	45



# Calibration Charts

## Calibration Chart - Small Hopper - Chart 4

"lbs. per acre"

Seed Type	Flute Engagement						
	3/16	1/4	3/8	1/2	3/4	1	1-1/8
<b>Sorghum</b>	<b>9</b>	<b>16</b>	<b>22</b>	<b>33</b>	<b>46</b>	<b>57</b>	<b>76</b>
<b>Kobe Lespedza</b>	<b>4</b>	<b>6</b>	<b>9</b>	<b>16</b>	<b>22</b>	<b>25</b>	<b>30</b>
<b>Korean Lespedza</b>	<b>6</b>	<b>9</b>	<b>15</b>	<b>24</b>	<b>36</b>	<b>43</b>	<b>52</b>
<b>Bi-Color Lespedza</b>	<b>10</b>	<b>18</b>	<b>24</b>	<b>33</b>	<b>48</b>	<b>64</b>	<b>75</b>
<b>Brown Top Millet</b>	<b>7</b>	<b>10</b>	<b>19</b>	<b>22</b>	<b>33</b>	<b>40</b>	<b>46</b>
<b>Japanese Millet</b>	<b>6</b>	<b>9</b>	<b>15</b>	<b>22</b>	<b>30</b>	<b>36</b>	<b>39</b>
<b>Hybrid Pearl Millet</b>	<b>12</b>	<b>19</b>	<b>25</b>	<b>33</b>	<b>52</b>	<b>72</b>	<b>88</b>
<b>Rape</b>	<b>9</b>	<b>13</b>	<b>18</b>	<b>25</b>	<b>43</b>	<b>60</b>	<b>82</b>
<b>Switchgrass</b>	<b>9</b>	<b>13</b>	<b>18</b>	<b>22</b>	<b>31</b>	<b>39</b>	<b>42</b>

### Seeds per Seed Box

#### Legume Seedbox (small hopper):

All small round types seeds that flow easily and are generally planted at a fairly low rate, typically from as low as 3 lbs. per acre to about 65 lbs. per acre. This would include all clover, alfalfa, brassicas and many flowers that have seed counts from about 100,000 seeds/lb to well over 7,000,000 seeds/lb. The seed size diameter would be from about 3/16" (5 mm) to as small as 1/128" (0.019 mm).

#### Large Seedbox:

All cereal grains, rye, wheat, oats barley and rice. Any seeds that are irregular shaped (elongated, rice shape) but still flow easily should be planted with this box. Most cool season grasses, such as fescue, ryegrass and bluegrass would be planted with this box. All types of beans, peas, corn and sunflowers can be planted with this box. Seed sizes would be from about 3/8" (9.5 mm) elongated up to about 3/8" (9.5 mm) diameter round. Seeding rates are typically from about 25 lbs. per acre to 400 lbs. per acre.

# Lubrication and Maintenance

**Important:** It is important to thoroughly clean the seeder after use. Failure to do so can cause irreparable damage to the seed cups and drive system. Grease and turn the Seed adjustment handle to ensure grease lubricates the threads.

- 1 Hour** Check all fasteners and hardware including set screws in sprockets and bearing collars and re-tighten as necessary.
- 8 Hours** Grease bearings and inspect chains for tightness.
- 25 Hours** Remove guard cover on right hand side of machine and inspect chain; lubricate using multi-purpose lithium base grease.
- As needed:** Remove any crop residue, grasses, weeds, or debris wrapped around shaft near bearings. This can cause bearings to overheat and lead to premature failure.
- Always:** Protect the machine from weather. NEVER leave fertilizer in hopper. Do not leave seed in hopper for more than 24 hours. Remove all fertilizer and seeds from hopper. Thoroughly clean hoppers and lubricate all drive chains before storage.

## Changing Discs

**Important:** When replacing the discs, it is extremely important to remember that one of the disc hubs has left hand threads and the other right hand threads. The threads can be stripped if removed improperly. Left side hub, turn Clockwise to loosen and turn counter-clockwise to tighten. Right side hub, turn counter-clockwise to loosen and clockwise to tighten.

Step 1: Remove the dust cap.

Step 2: Remove the external scraper dust cap.

Step 3: Remove hub nuts.







Step 4: Unscrew the hub from the disc support.

Step 5: Replace the discs and reassemble.



**Important:** When replacing the discs, it is extremely important to remember that the left disc hub has reverse (LH) threads. The right disc hub has normal (RH) threads. If turned incorrectly, they can strip.

# Torque Specifications

Torque Specifications for Common Bolt Sizes															
Inches		Bolt Head Identification						Metric		Bolt Head Identification					
															
Bolt size (inches)	Thread pitch	Grade 2		Grade 5		Grade 8		Bolt size (metric)	Thread pitch	Class 5.8		Class 8.8		Class 10.9	
		N.m	ft-lb	N.m	ft-lb	N.m	ft-lb			N.m	ft-lb	N.m	ft-lb	N.m	ft-lb
1/4"	20	7	5	11	8	16	12	M5	0.08	4	3	6	4	9	7
1/4"	28	8	6	13	10	19	14	M6	1	6	4	10	7	15	11
5/16"	18	15	11	24	17	33	25	M8	1.25	16	12	25	18	36	27
5/16"	24	17	13	26	19	37	27	M8	1	17	13	26	19	38	28
3/8"	16	27	20	42	31	59	44	M10	1.5	31	23	48	35	71	52
3/8"	24	31	23	47	35	67	49	M10	1.25	33	24	51	38	75	55
7/16"	14	43	32	67	49	95	70	M10	1	35	26	53	39	78	58
7/16"	20	48	36	75	55	106	78	M12	1.75	54	40	84	62	123	91
1/2"	13	66	48	102	75	144	106	M12	1.5	56	41	87	64	128	94
1/2"	20	75	55	115	85	163	120	M12	1.25	59	44	90	66	133	98
9/16"	12	95	70	147	109	208	154	M14	2	84	62	133	98	195	144
9/16"	18	106	79	164	121	232	171	M14	1.5	94	69	142	105	209	154
5/8"	11	132	97	203	150	287	212	M16	2	131	97	206	152	302	223
5/8"	18	149	110	230	170	325	240	M16	1.5	141	104	218	161	320	236
3/4"	10	233	172	361	266	509	376	M18	2.5	181	133	295	218	421	310
3/4"	16	261	192	403	297	569	420	M18	2	196	145	311	229	443	327
7/8"	9	226	167	582	430	822	606	M18	1.5	203	150	327	241	465	343
7/8"	14	249	184	642	473	906	668	M20	2.5	256	189	415	306	592	437
1"	8	339	250	873	644	1232	909	M20	1.5	288	212	454	335	646	476
1"	12	371	273	955	704	1348	995	M22	2.5	344	254	567	418	807	595
1-1/8"	7	480	354	1077	794	1746	1288	M22	1.5	381	281	613	452	873	644
1-1/8"	12	539	397	1208	891	1958	1445	M24	3	444	327	714	526	1017	750
1-1/4"	7	677	500	1519	1120	2463	1817	M24	2	488	360	769	567	1095	808
1-1/4"	12	750	553	1682	1241	2728	2012	M27	3	656	484	1050	774	1496	1103
1-3/8"	6	888	655	1992	1469	3230	2382	M27	2	719	530	1119	825	1594	1176
1-3/8"	12	1011	746	2268	1673	3677	2712	M30	3.5	906	668	1420	1047	2033	1499
1-1/2"	6	1179	869	2643	1949	4286	3161	M30	2	1000	738	1600	1180	2250	1659
1-1/2"	12	1326	978	2974	2194	4823	3557	M36	4	1534	1131	2482	1830	3535	2607

## Notes:

This chart is an approximate estimate of torque values.

Always tighten hardware to these values unless a different torque value or tightening procedure is listed for a specific application.

Fasteners must always be replaced with the same grade as specified in the manual.

Always use the proper tool for tightening hardware: SAE for SAE hardware and Metric for Metric hardware.

Make sure that fastener threads are clean and that you properly start thread engagement.

**Page left blank intentionally**



# **Food Plotter No Till Drill HDNT-65**



## **Parts Manual**

# Large Hopper

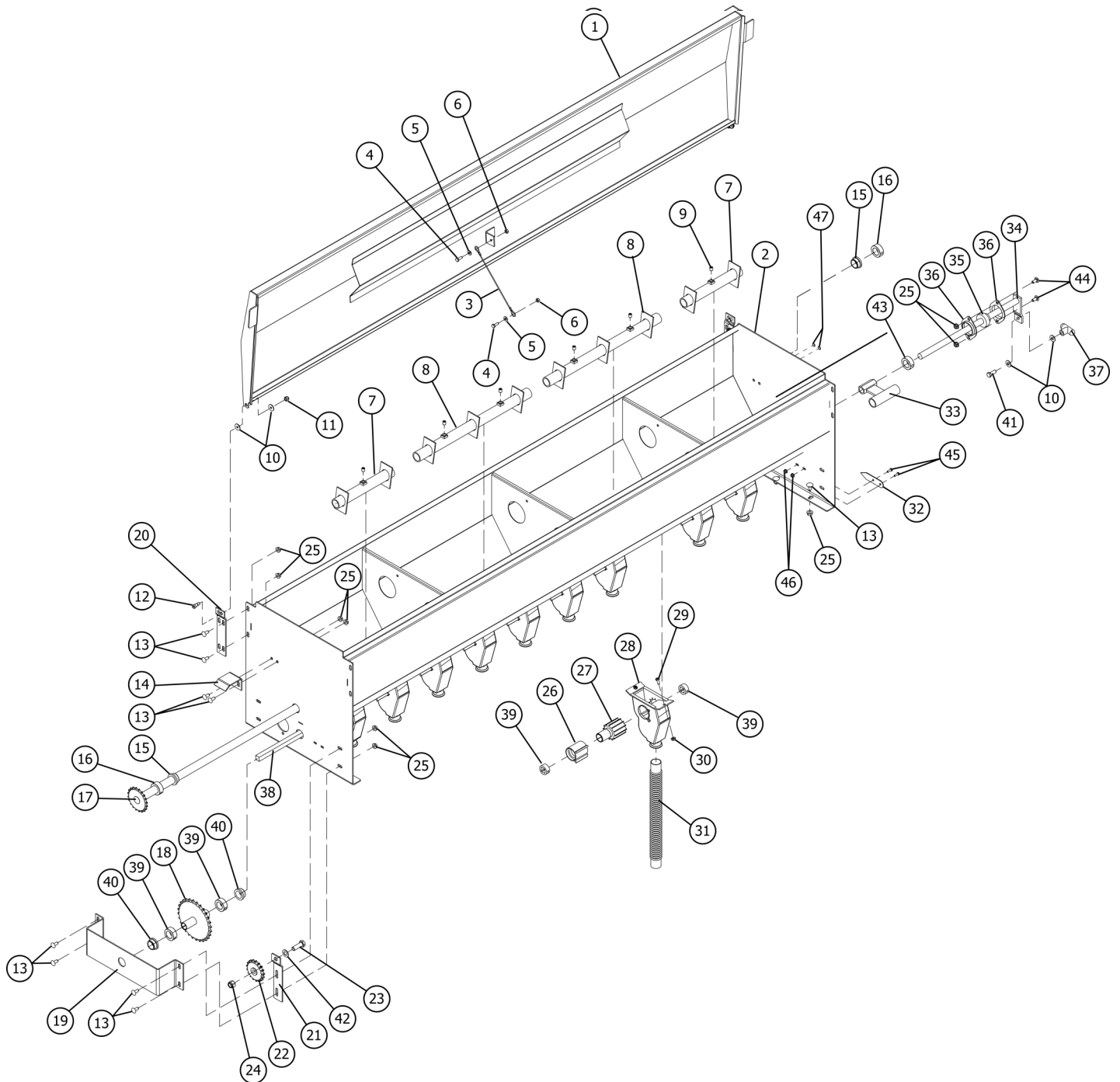

## Large Hopper

Item	Part #	Description	Qty.
1	SB101332	Large hopper lid weldment 7'	1
2	SB101328	Large hopper weldment 7"	1
3	SB117496	Lid cable	1
4	SB500118	Bolt, HH 1/4"-20 x 3/4"	2
5	SB500051	Washer, flat 1/4"-20	2
6	SB500119	Nut, HH 1/4"-20 x 3/4" Gr 2	2
7	SB101357	Agitator weldment 7" small	2
8	SB101358	Agitator weldment 7" large	2
9	SB500164	Set screw 3/8"-16 x 1/2"	6
10	SB100732	Washer, plastic 3/8"	6
11	SB500163	Nut, elastic stop 5/16"-18 Gr 2	2
12	SB500120	Shoulder bolt 5/16"-18	2
13	SB100139	Bolt, carriage 3/8"-16 x 3/4" Gr 5	16
14	SB100592	Guard mounting clip	1
15	SB100691	IGUS bearing MFI1620-10	2
16	SB100690	Shaft collar 1" bore	2
17	SB101344	Large hopper agitator shaft weldment 7'	1
18	SB100633	Drive assembly weldment	1
19	SB101337	Outboard bracket 7'	1
20	SB100289	Universal lid mounting plate 7'	2
21	SB100478	Bracket, idler sprocket	1
22	SB100625	Sprocket, idler	1
23	SB500106	Bolt, HH 1/2"-13 x 1-1/2" Gr 5	1
24	SB500109	Nut, elastic stop 1/2"-13 Gr 2	1
25	SB500121	Nut, flange 3/8"-16 Gr 5	16
26	SB100642	Seed cup spacer	10
27	SB100641	Seed cup gear	10
28	SB100643	Seed cup housing	10
29	SB500124	Machine screw truss head Phillips 1/4"-20 x 5/8" Gr 5	20
30	SB500125	Nut, flange 1/4"-20 Gr 2	20
31	SA3002	Fertilizer/seed tube	10
32	SB100593	Pointer	1
33	SB100628	Seed rate adjustment	1
34	SB101749	Shaft, seed rate adjustment	1
35	SB101647	Bearing housing	2
36	SB100646	Bearing	1
37	SB101287	Handle	1
38	SB101342	Drive shaft large hopper 7'	1

# Large Hopper

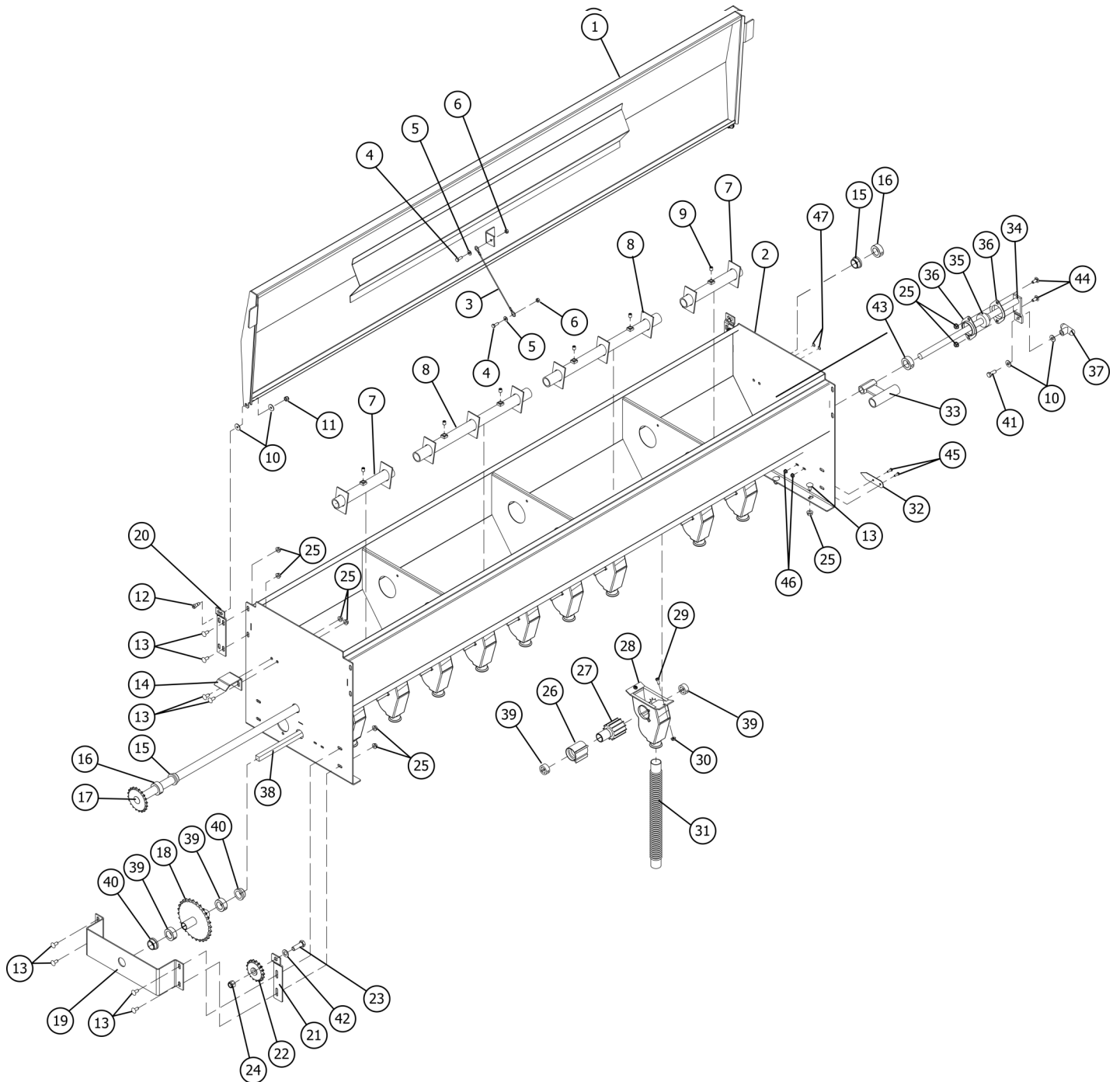



## Large Hopper

<b>Item</b>	<b>Part #</b>	<b>Description</b>	<b>Qty.</b>
39	SB100476	Shaft collar 7/8" bore	18
40	SB100691	IGUS bearing MFI1620-10 for 7/8" shaft collar	2
41	SB500131	Bolt, HH 3/8"-16 x 1" Gr 5	1
42	SB500055	Washer, flat 1/2"	1
43	SB100744	Shaft collar 3/4" bore	1
44	SB500116	Bolt, carriage 5/16"-18 x 3/4"	2
45	SB500122	Machine screw truss head Phillips #10-24 x 5/8" Gr 5	2
46	SB500123	Nut, flange #10-24 Gr 5	2
47	SB100913	Plug, plastic 11/32" hole (9688K241)	2

# Small Hopper

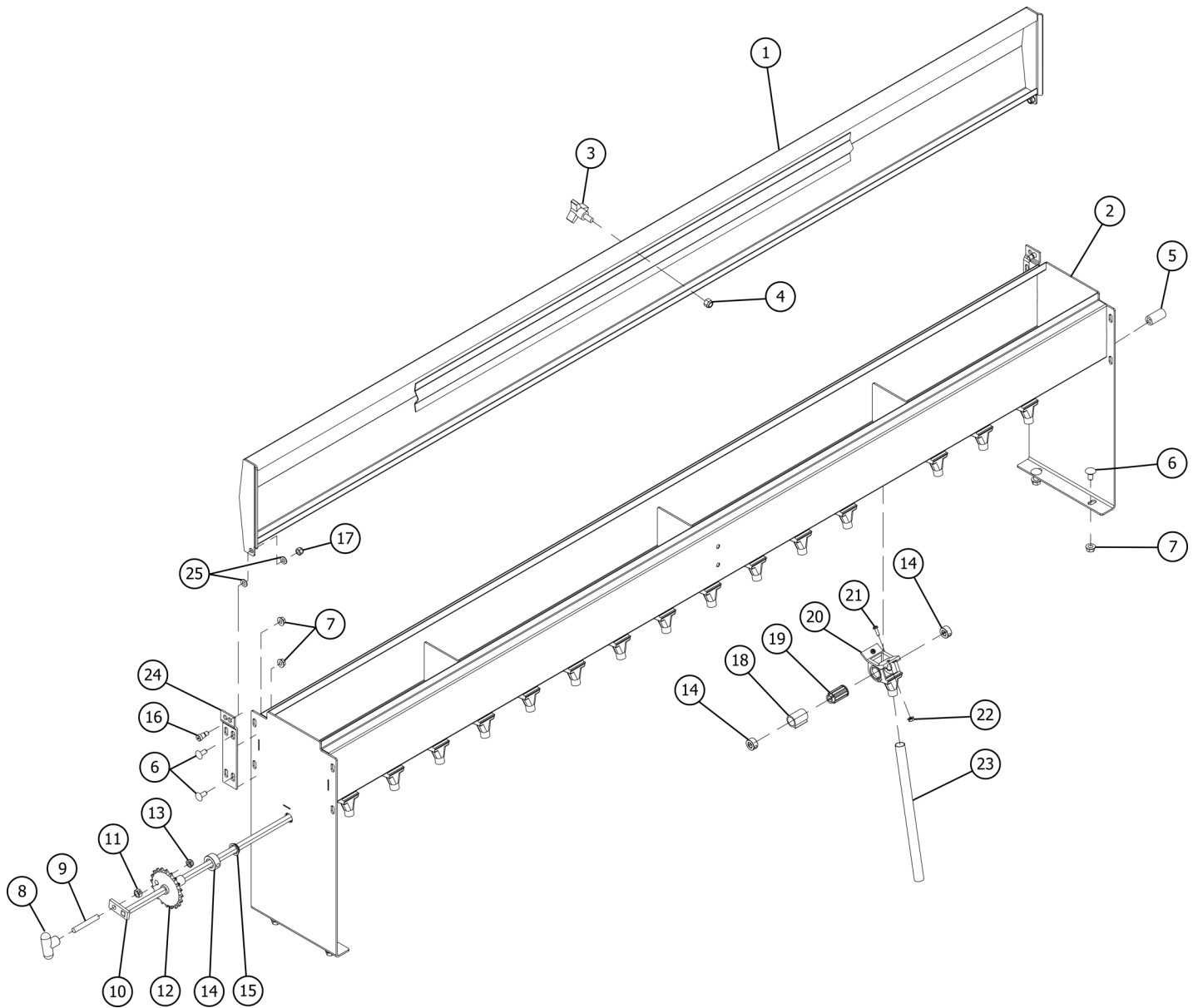

## Small Hopper

Item	Part #	Description	Qty.
1	SB101331	Small hopper lid weldment	1
2	SB101325	Small hopper weldment	1
3	SB100617	Knob	1
4	SB500110	Nut, elastic stop 3/8"-16 Gr 5	1
5	SB101607	Spacer, small decal scale	1
6	SB500139	Bolt, carriage 3/8"-16 x 3/4" Gr 5	8
7	SB500121	Nut, flange 3/8"-16 Gr. 5	8
8	SB101287	Adjustment knob	1
9	SB101284	Threaded knob with shoulder	1
10	SB101335	Driveshaft weldment small hopper	1
11	SB500186	Nut, jam 3/8"-16 Gr 5	1
12	SB100718	Small hopper drive sprocket weldment	1
13	SB500110	Nut, elastic stop 3/8"-16 Gr 5	1
14	SB100744	Shaft collar 3/4" bore	1
15	SB101341	IGUS clip bearing MCI-12-02	1
16	SB500120	Shoulder bolt 5/16"-18	2
17	SB500163	Nut, elastic stop 5/16"-18 Gr 2	2
18	SB100708	Precision legume cup spacer	10
19	SB100709	Precision legume cup gear	10
20	SB100710	Precision legume cup housing	10
21	SB500122	Machine screw truss head Phillips 10-24 x 5/8" Gr 5	20
22	SB500123	Nut, flange #10-24 Gr 5	20
23	SB10000200	Feed tube	10
24	SB100289	Universal lid mounting plate	2
25	SB100732	Washer, plastic 3/8"	4

# Roller Chain

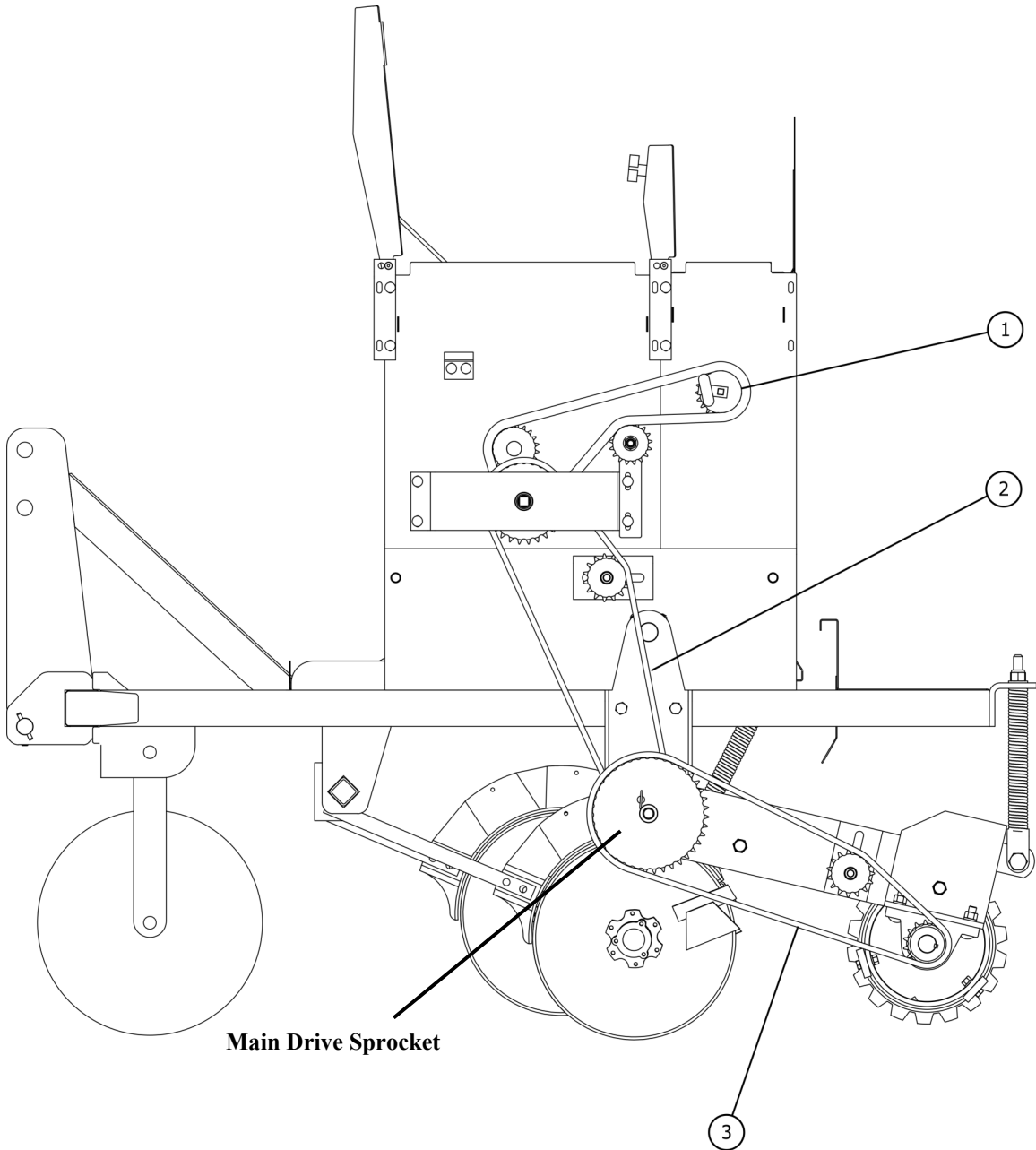

## Roller Chain

Item	Part #	Description	Qty.
1	SB10000202	Roller Chain #40 x 89 links (small hopper drive)	1
2	SB135209	Roller Chain #50 X 99 links (large hopper drive)	1
3*	SB135208	Roller Chain #50 X 91 links (main drive)( <b>units w/28 tooth sprocket</b> )	1
	SB136379	Roller Chain #50 X 96 links (main drive)( <b>units w/40 tooth sprocket</b> )	1

\*NOTE: Before ordering item #3 Roller Chain, be sure to check the number of teeth on the main drive sprocket. Some units are equipped a 28 tooth sprocket and some with 40 tooth sprocket. See page 33 for details.

# Frame Assembly

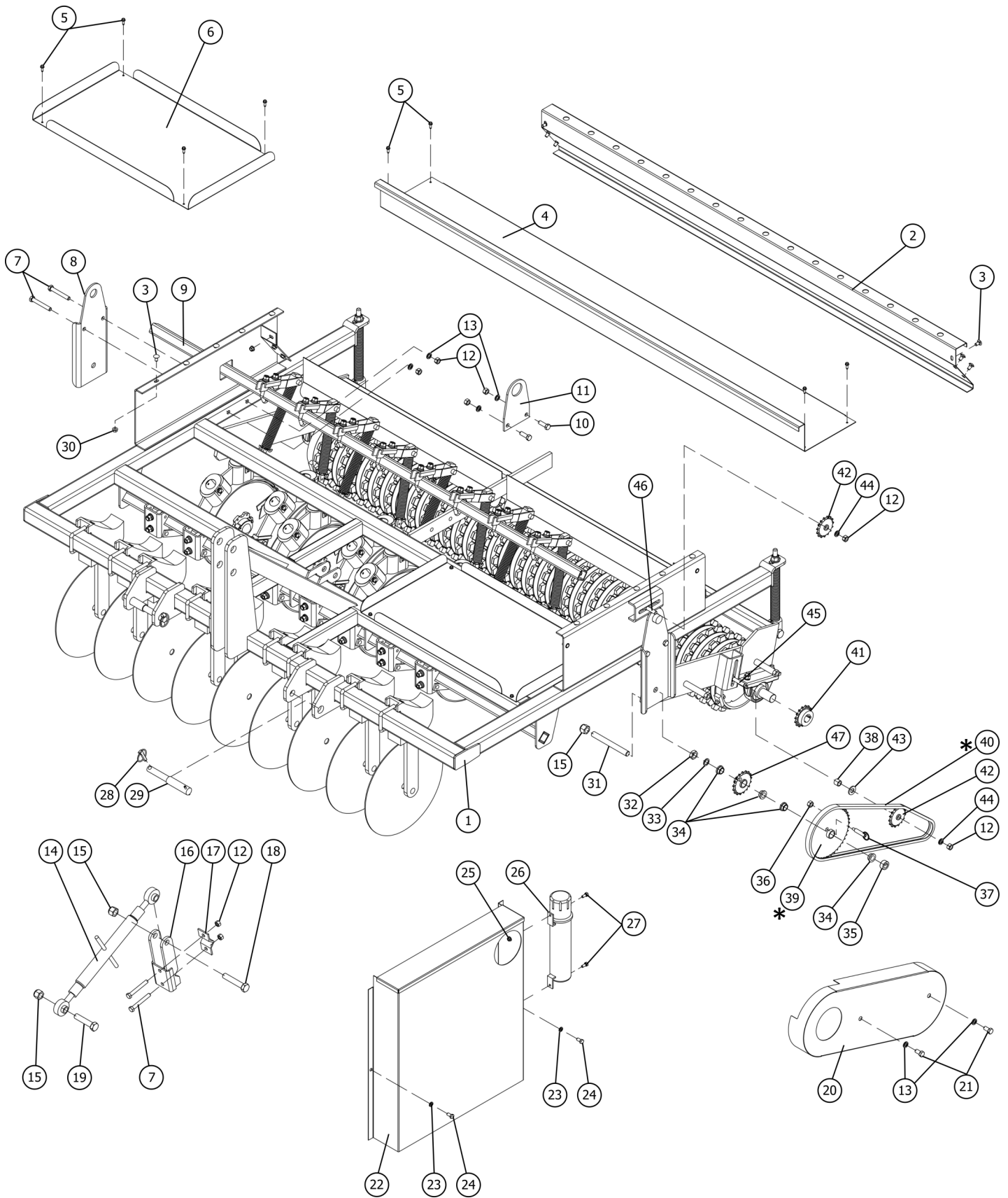

\* See Note, page 33

## Frame Assembly

Item	Part #	Description	Qty.
1	SB135614	Seeder frame weldment	1
2	SB135233	Scatter pan Greenscape 750	1
3	SB500139	Bolt, carriage 3/8"-16x3/4" Gr 5	16
4	SB135237	Rear cover sheet weldment	1
5	SB500607	Screw, self tapping 1/4" x 3/4"	12
6	SB135363	Seeder front cover pan	1
7	SB500103	Bolt HH 1/2"-13 x 3-1/2" Gr 5	4
8	SB135174	Rear pivot tubing mount plate	2
9	SB135197	Pivot tube weldment	1
10	SB500106	Bolt HH 1/2"-13 x 1-1/2" Gr 5	2
11	SB135180	Pivot tube mount plate center	1
12	SB500104	Nut, HH 1/2"-13 Gr 2	6
13	SB500073	Washer, lock 1/2"	6
14	SB100757	Adjustable rear arm	1
15	SB500113	Nut, elastic stop 3/4"-10 Gr 2	2
16	SB135366	Top link weldment	1
17	SB136296	Backing plate	1
18	SB500253	Bolt, HH 3/4"-10 x 4.00" Gr 5	1
19	SB500126	Bolt, HH 3/4"-10 x 3-1/2" Gr 5	1
20	SB135352	Lower guard weldment	1
21	SB500156	Bolt, HH 1/2"-13 x 1.00" Gr 5	2
22	SB135348	Upper guard weldment	1
23	SB500071	Washer, lock 3/8"	2
24	SB500131	Bolt, HH 3/8"-16 x 1.00"	2
25	SB500121	Nut, flange 5/16"-18	2
26	MH10000	Manual holder	1
27	SB500116	Bolt, HH 5/16"-18 x 3/4" Gr 5	2
28	SB100756	Lynch pin 7/16" x 1-3/4"	2
29	SB100755	Hitch pin assembly	2
30	SB500132	Nut, flange 3/8"-16 Gr 2	16
31	SB135863	Sprocket mount stub updated	1
32	SB500127	Nut jam 3/4"-10 Gr 2	1
33	SB100743	IGUS thrust washer MTI-12	1
34	SB100741	IGUS bearing MFI 1216-08	4
35	SB100744	Shaft collar 3/4" bore	1
36	SB500104	Nut HH 1/2"-13 Gr 2	1
37	SB100736	Threaded lock pin	1
38	SB136256	Idler sprocket spacer pipe	1

# Frame Assembly

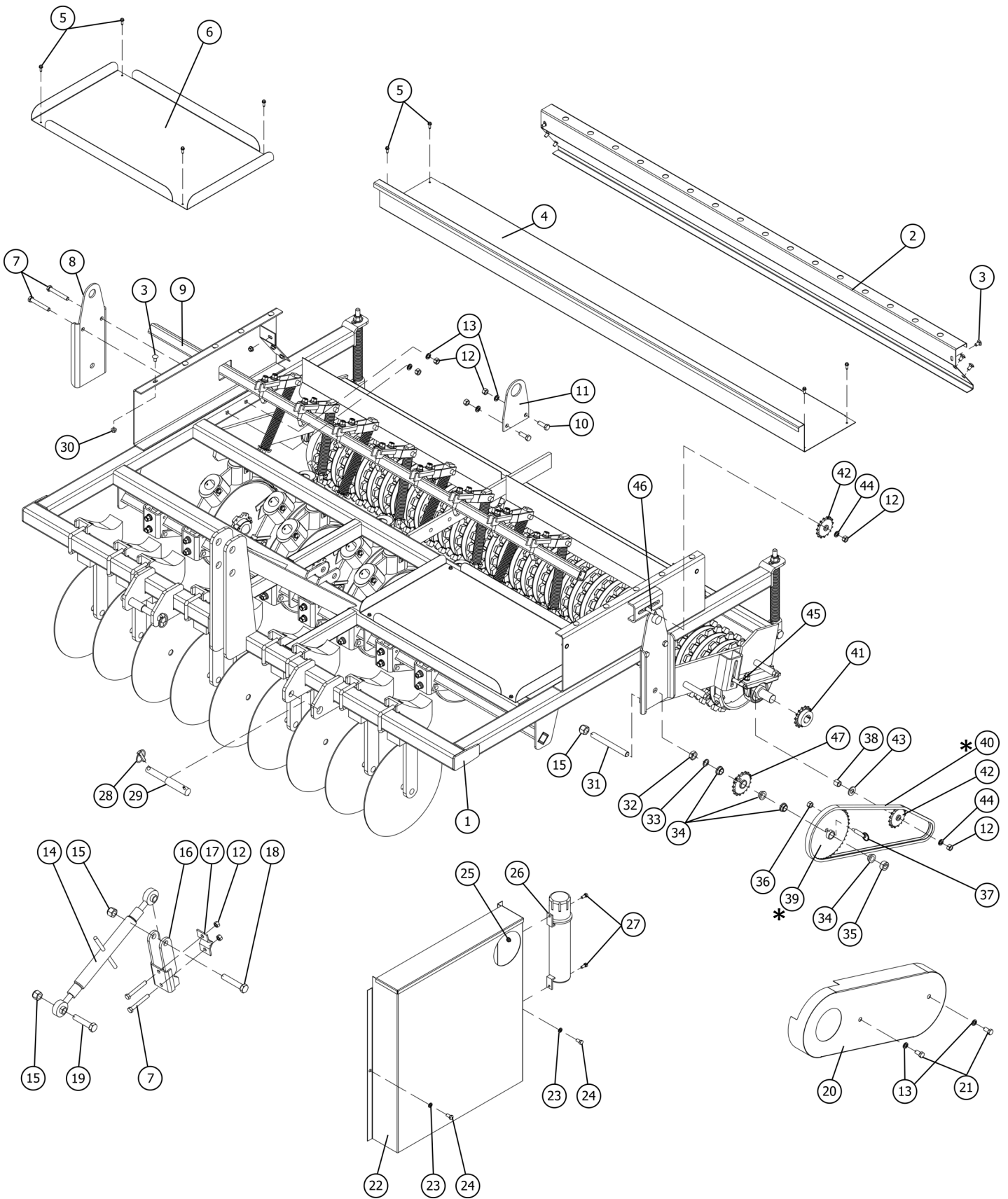

\* See Note, page 33



## Frame Assembly

Item	Part #	Description	Qty.
39*	SB101576	Transmission small sprocket weldment ( <b>28 tooth</b> )	1
	SB100740	Transmission large sprocket weldment ( <b>40 tooth</b> )	1
40*	SB135208	Roller Chain #50 x 91 links ( <b>fits 28 tooth sprocket only!</b> )	1
	SB136379	Roller Chain #50 x 96 links ( <b>fits 40 tooth sprocket only!</b> )	1
41	SB100733	Sprocket 50BS15H (1-1/4" bore)	1
42	SB100745	Idler sprocket 50BB15H x 1/2"	1
43	SB500057	Washer flat 5/8"	1
44	SB500073	Washer lock 1/2"	1
45	SB500138	Bolt carriage 1/2"-13 x 1.00" Gr 5	1
46	SB500133	Bolt carriage 1/2"-13 x 2.00" Gr 5	1
47	SB135210	750 transmission small sprocket weldment	1

**\*NOTE:** Prior to ordering sprocket #39 or roller chain #40, check the serial number of the unit. Serial numbers 25001 thru 25008 use part numbers SB101576 Sprocket (**28 teeth**) and SB135208 Roller Chain (**91 links**). All others use SB100740 Sprocket (**40 tooth**) and SB136379 Roller Chain (**96 links**). If the Serial Number is not legible, identify the sprocket by counting the number of teeth, (**28 or 40**).

# Coulter Assembly

RH Coulter Assembly

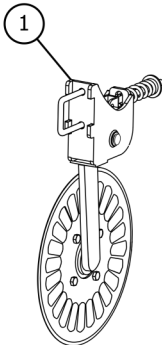

LH Coulter Assembly

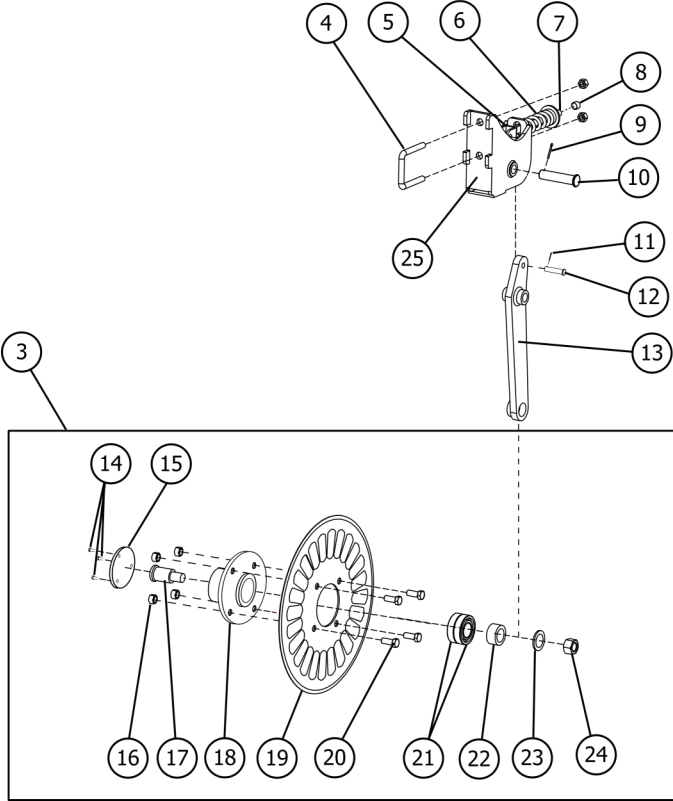
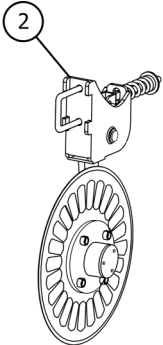

**Note:** Item 3, PN SA7001 Coulter Disc Complete is used on the LH and RH Coulter Assembly. The difference is the side the hub is on. The hub faces the RH side of the implement on the RH Coulter Assembly and opposite for the LH Assembly. Refer to the two images at the top of the page.

## Coulter Assembly

Item	Part #	Description	Qty.
1	SA8008R	Coulter kit - RH	5
2	SA8008L	Coulter kit - LH	5
3	SA7001	Coulter disc complete	10
4	SA8006	U-bolt	10
5	SA8005	Coulter spring arm	10
6	SA8004	Coulter spring	10
7	LNM1620	Self locking nut M16-2.0	10
8	SA4008	Cap	10
9	CP5x40	Cotter pin M5x40	10
10	SA8010	Lower hitch pin 20x90	40
11	CP3x35	Cotter pin M3x35	10
12	SA4010	Clevis pin M10x35	10
13	SA8000	Coulter support arm	10
14	BM061010	Bolt M6-1.0x10	30
15	SA9013	Cover	10
16	LNM12175	Nut	40
17	SA8011	Special bolt	10
18	SA8003	Coulter bearing housing	10
19	SA8002	Coulter disc	10
20	BM1217535	Bolt	40
21	B62062RS	Bearing	20
22	SA9008	Spacer M30x42x9	10
23	FW20	Flat washer	10
24	LNM2025	Nut	10
25	SA8001	Coulter support bracket	10

# Disc Assembly

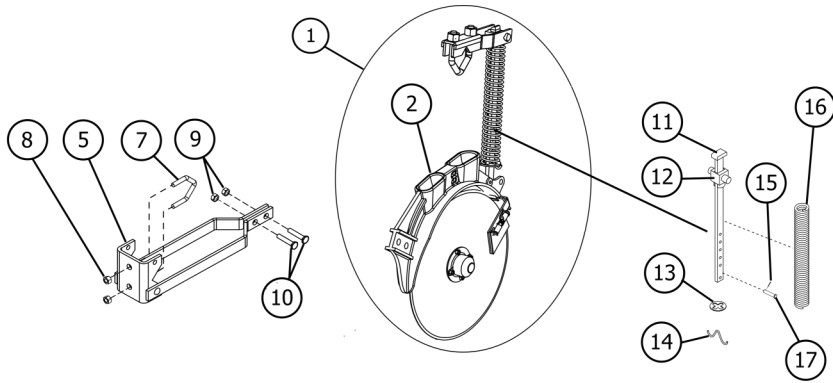

**Front Disc Assembly**

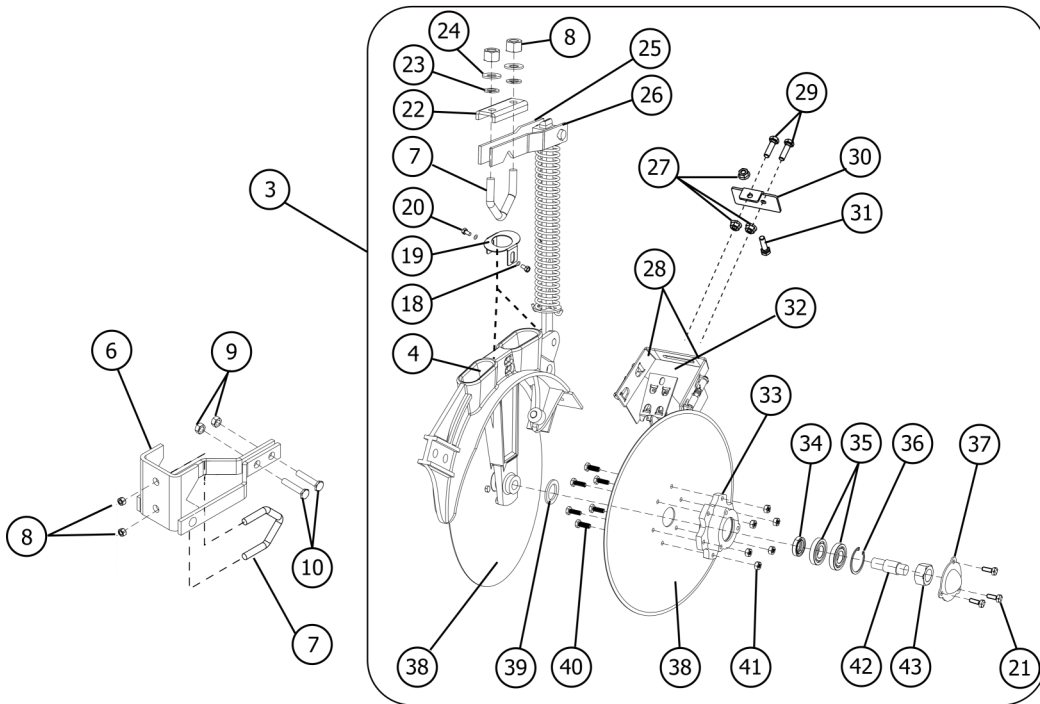

**Rear Disc Assembly**

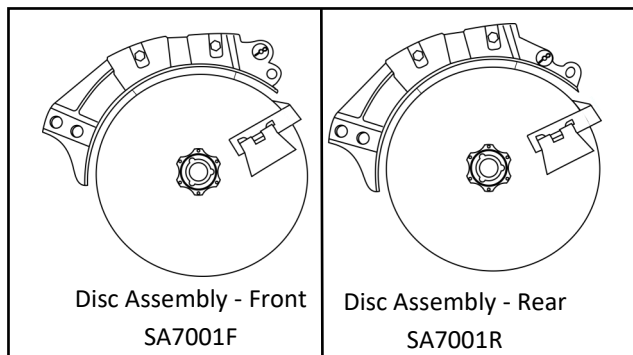

## Disc Assembly

Item	Part #	Description	Qty.
1	SA7001R	Disc assembly complete, rear	5
2	SA7007	Seed drill casting, rear	5
3	SA7001F	Disc assembly complete, front	5
4	SA7006	Seed drill casting, front	5
5	SA6001	Disc support bracket long (rear)	5
6	SA6002	Disc support bracket short (front)	5
7	SA7003	V-bolt M12x1.75	20
8	NM12175	Nut M12-1.75	40
9	NM1215	Nut M12 x 1.5	20
10	BM121535	Bolt M12-1.5x35	20
11	SA4023	Damper rod	10
12	SA4024	Damper guide	10
13	SA4025	Star washer	10
14	SA4026	Retainer clip	10
15	CP2.5x20	Cotter pin M2.5x20	10
16	SA7002	Disc spring for support assembly	10
17	SA6010	Pin, clevis M6x40	10
18	FW08	Flat washer M08	40
19	SA3001	Seed tube retainer	20
20	BM0812510	Bolt HH M08-1.25x10	40
21	BM061012	Bolt M6-1.0x12	60
22	SA6003	Disc support	10
23	LW12	Lock washer M12	20
24	FW12	Flat washer M12	20
25	SA7004	Top coulter support bracket, left	10
26	SA7004R	Top coulter support bracket, right	10
27	FN08125	Flanged nut M8-1.25	30
28	DL6007	External scraper	20
29	BM0812520	Bolt M8-1.25x20	20
30	SA6011	Scraper mount bracket	10
31	BM0812520	Bolt M8-1.25x20	10
32	DL6006	Internal scraper	10
33	SA6005	Disc support bearing (bearing only)	20
34	OS203207	Oil seal - M20x32x7	40
35	B6004RS	Bearing 6004 2RS (2 per side)	40
36	SRI-45	Snap ring - internal - M45	20
37	SA6009	Bearing grease cap	20
38	SA6004	Disc, single	20
39	FW16	Washer flat M16	20

# Disc Assembly

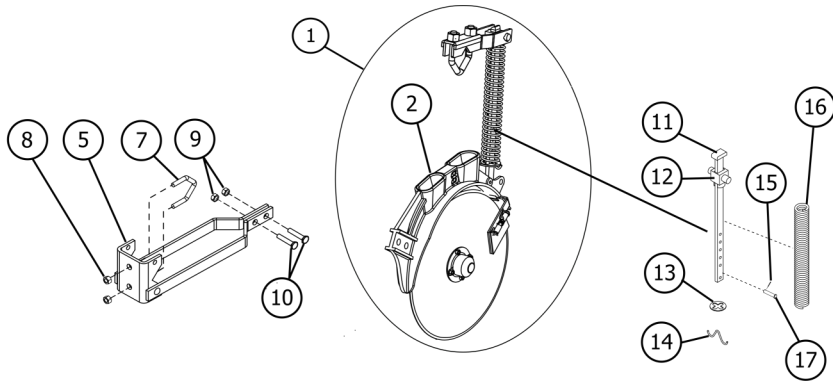

**Front Disc Assembly**

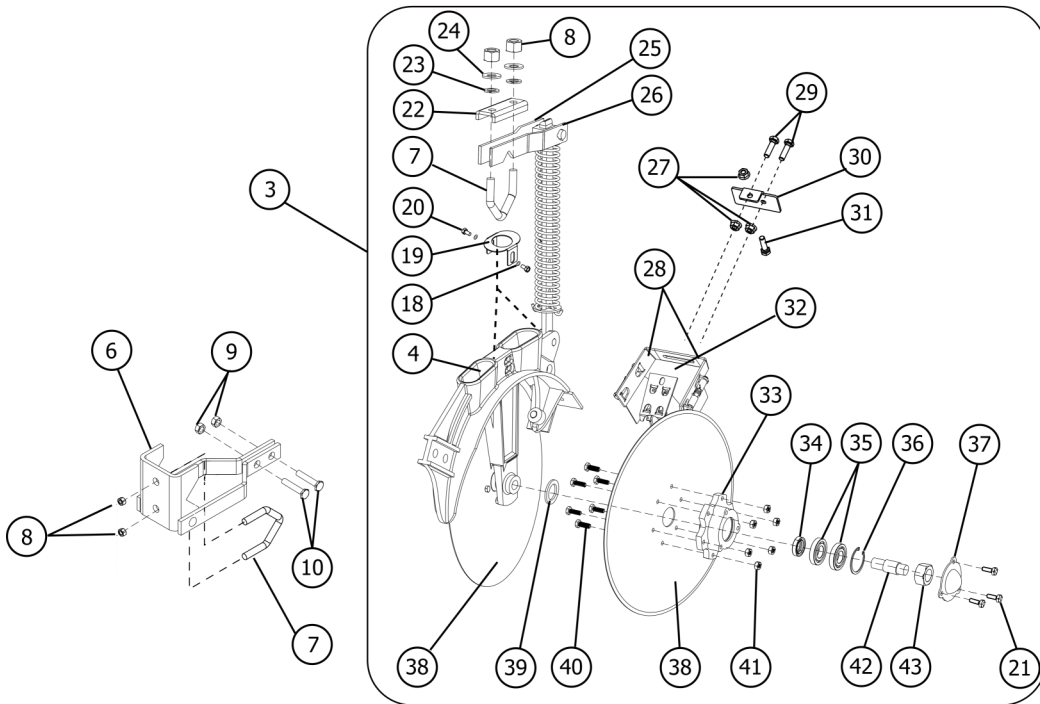

**Rear Disc Assembly**

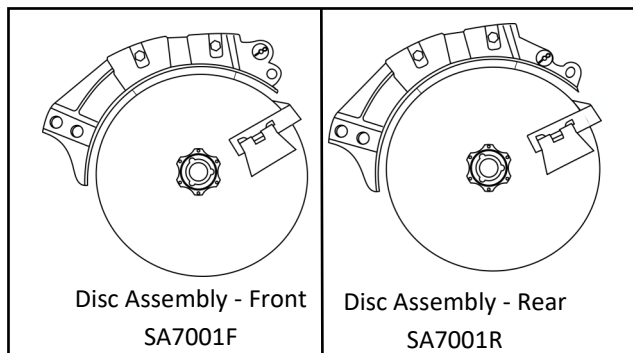

## Disc Assembly

Item	Part #	Description	Qty.
40	BM061025	Bolt M6-1.0x25	60
41	NM0610	Nut M6-1.0	60
42	SA4027	Stud, disc assembly <b>*Warning! See note below.</b>	10
	SA4028	Stud, disc assembly <b>*Warning! See note below.</b>	10
43	NM1620L	Nut M16-2.0 LH threads (for SA4027 LH stud only)	10
	NM1620	Nut M16-2.0 (for SA4028 RH stud only)	10

**Note: Warning! When removing/replacing Disc Assembly Studs note that the LH & RH studs have different thread patterns! Using the wrong stud will cause damage to the stud and or the seed drill casting!**

*SA4027 Stud, disc assembly LH* has LH threads on both ends of the stud. *SA4028 Stud, disc assembly RH* has RH threads on both ends of the stud. These parts are not interchangeable! The LH stud must be used on the LH side of the Seed drill casting. The RH stud must be used on the RH side of the Seed drill casting.

**Removing Disc Assembly studs:**

LH - Facing the LH side of the Disc Assembly, turn the nut on the stud in a clockwise rotation.

RH - Facing the RH side of the Disc Assembly, turn the nut on the stud in a counter-clockwise rotation.

**Re-attaching Disc Assembly studs:**

LH - Facing the LH side of the Disc Assembly, turn the nut on the stud in a counter-clockwise rotation.

RH - Facing the RH side of the Disc Assembly, turn the nut on the stud in a clockwise rotation.

# Cultipacker

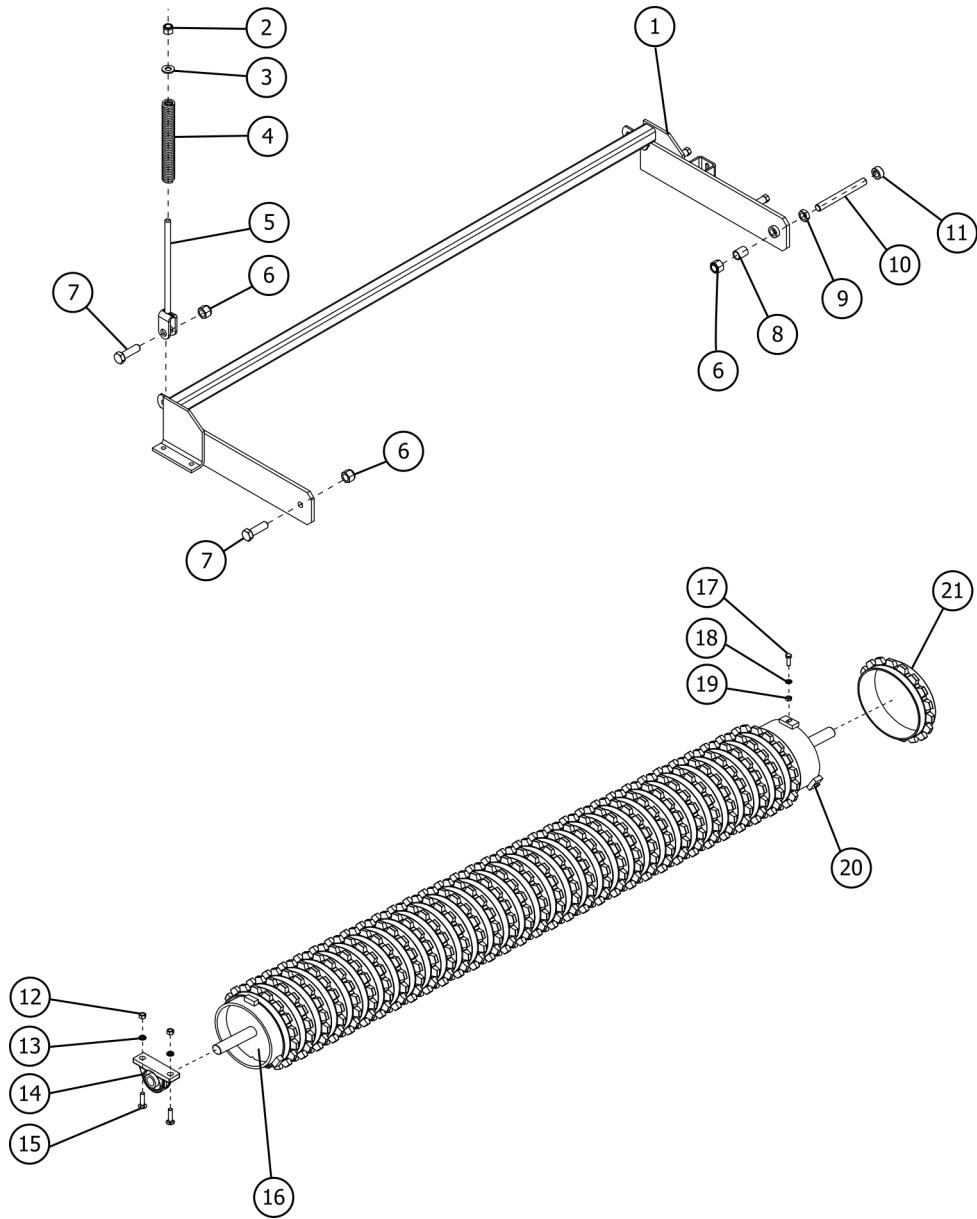



# Cultipacker

Item	Part #	Description	Qty.
1	SB135200	Cultipacker frame weldment	1
2	SB500193	Nut nylock 5/8"-11 Gr 2	2
3	SB500057	Washer flat 5/8"	3
4	DL8004	Spring	2
5	SB135214	Cultipacker adjustment mount weldment	2
6	SB500113	Nut nylock 3/4"-10 Gr 2	6
7	SB500161	Bolt HH 3/4"-10x2-1/2" Gr 5	3
8	SB135313	Cultipacker pivot sleeve	1
9	SB500127	Nut jam 3/4"-10 Gr 2	1
10	SB135863	Sprocket mount stub	1
11	SB100744	Shaft collar 3/4" BORE	1
12	SB500104	Nut HH 1/2"-13 Gr 2	4
13	SB500073	Washer lock 1/2"	4
14	SB100497	Pillow block bearing 1-1/4" (NAP207-20)	2
15	SB500133	Bolt carriage 1/2"-13x2.00 Gr 5	4
16	SB135198	Cultipacker roller weldment	1
17	SB500129	Bolt HH 3/8"-16x1-1/4" Gr 5	3
18	SB500071	Washer lock 3/8"	3
19	SB500115	Nut HH 3/8"-16 Gr 2	3
20	SB100472	Disc retaining tab w/hole	3
21	SB100676	Nylon cultipacker ring	34

# Decals

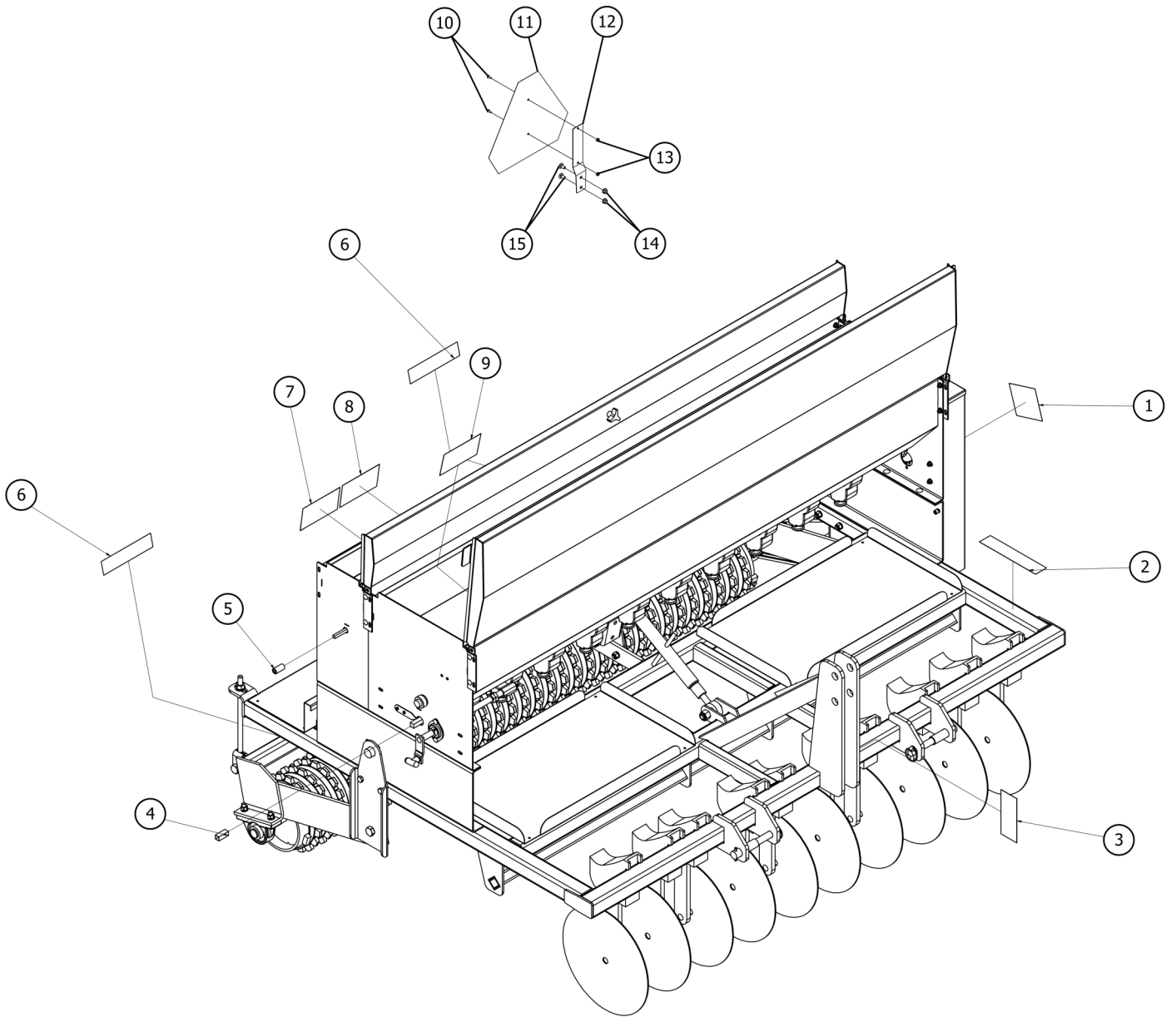

## Decals

Item	Part #	Description	Qty.
1	SB100759	Decal Caution	1
2	SB101400	Decal Warning falling off	1
3	SB101401	Decal Warning Crush/Pinch	1
4	SB101177	Decal Scale large hopper	1
5	SB101178	Decal Scale small hopper	1
6	SB101379	Decal Red reflective strip 2" x 9"	2
7	SB135715	Decal Small hopper calibration Chart 3	1
8	SB135716	Decal Small hopper calibration Chart 4	1
9	SB135714	Decal Large hopper calibration Chart 2	1
10	SB500122	Machine screw truss head Phillips #10-32 x 5/8"	2
11	SB10180	SMV emblem	1
12	SB101181	SMV offset bracket	1
13	SB500123	Nut, flange #10-24	2
14	5SB500117	Nut, flange 5/16"-18 G2	2
15	5SB500169	Bolt, carriage 5/16"-18 x 3/4" G5	2

# Warranty

## **LIMITED WARRANTY**

LMC warrants to the original purchaser of any new piece of machinery from LMC, purchased from an authorized LMC dealer, that the equipment be free from defects in material and workmanship for a period of one (1) year for non-commercial, state, and municipalities' use, ninety (90) days for commercial use from date of retail sale. Warranty for rental purposes is thirty (30) days. The obligation of LMC to the purchaser under this warranty is limited to the repair or replacement of defective parts.

Replacement or repair parts installed in the equipment covered by this limited warranty are warranted for ninety (90) days from the date of purchase of such part or to the expiration of the applicable new equipment warranty period, whichever occurs later. Warranted parts shall be provided at no cost to the user at an authorized LMC dealer during regular working hours. LMC reserves the right to inspect any equipment or parts, which are claimed to have been defective in material or workmanship.

This limited warranty does not apply to and excludes wear items such as shear pins, tires, tubes knives, blades or other wear items. Oil or grease is not covered by this warranty.

All obligations of LMC under this limited warranty shall be terminated if:

- Proper service is not performed on the machine.

- The machine is modified or altered in any way.

- The machine is being used or has been used for purposes other than those for which the machine was intended.

## **DISCLAIMER OF IMPLIED WARRANTIES & CONSEQUENTIAL DAMAGES**

LMC obligation under this limited warranty, to the extent allowed by law, is in lieu of all warranties, implied or expressed, including implied warranties of merchantability and fitness for a particular purpose and any liability for incidental and consequential damages with respect to the sale or use of the items warranted. Such incidental and consequential damages shall include but not be limited to: transportation charges other than normal freight charges; cost of installation other than cost approved by LMC; duty; taxes; charges for normal service or adjustment; loss of crops or any other loss of income; rental of substitute equipment, expenses due to loss, damage, detention or delay in the delivery.

**Page left blank intentionally**



1715 South Slappey Blvd  
Albany, GA 31701  
800-673-6369  
[www.lmcag.com](http://www.lmcag.com)